

# DENISON HYDRAULICS

## Pressure Controls – Flanged Type

### Series R5 with 3 ports

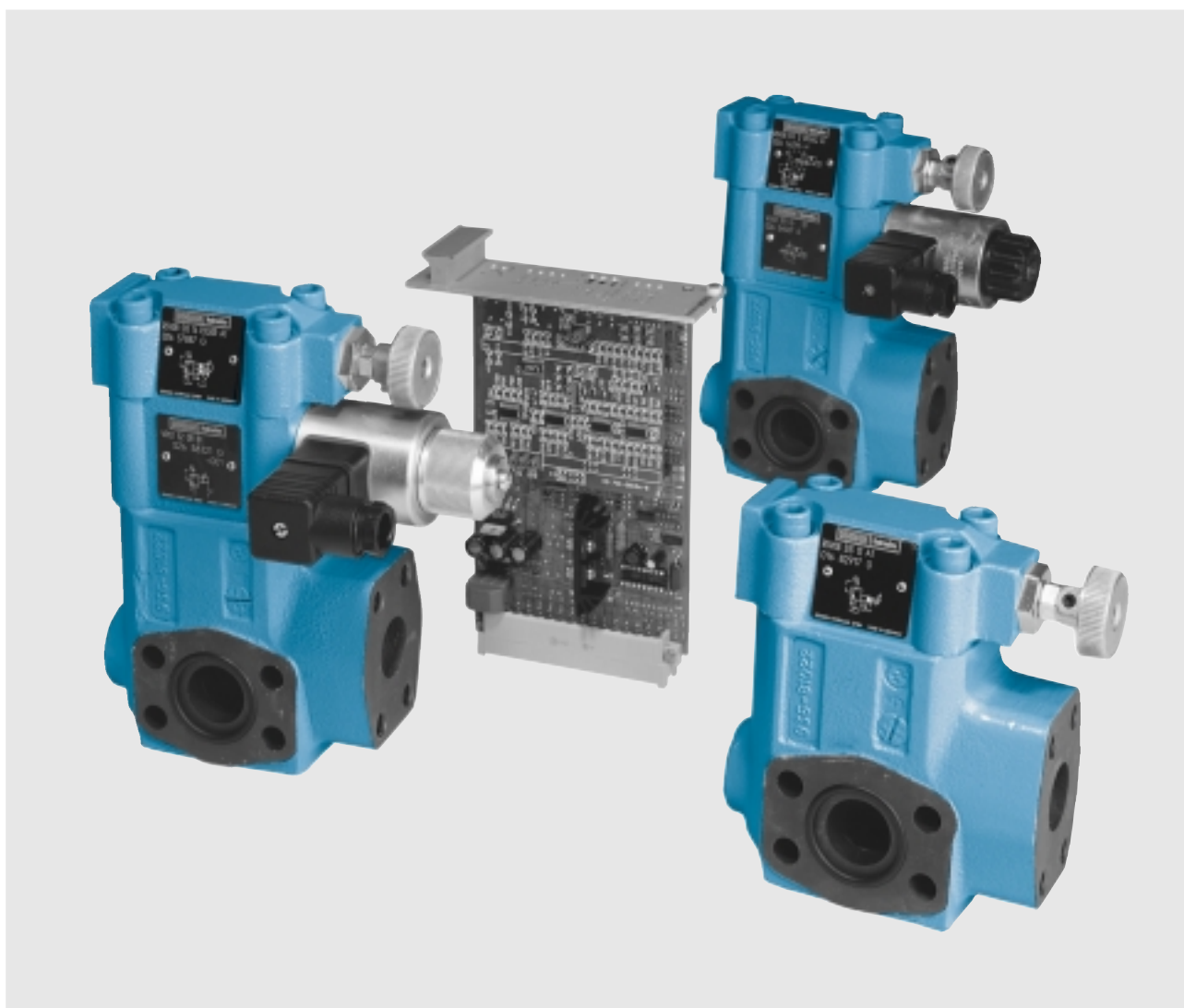

Publ. 3-EN 2900-C (dig.)

**DENISON** Hydraulics

## FEATURES, SYMBOL

### FEATURES

- **Increase Operating Safety:** Flange mounted valves as illustrated in this bulletin increase operating safety and reduce mounting costs. The R5 range of flange bodied pressure controls enable the valves to be mounted directly on an SAE pump outlet flange, ensuring maximum pump protection against peak pressure and eliminating costly piping.
- **High Performance:** R5 valves are designed for a maximum adjustable pressure up to 350 bar and a flow capacity ranging from 90 l/min ( $\frac{3}{4}$ " to 600 l/min ( $1\frac{1}{4}$ " and  $1\frac{1}{2}$ "). The pilot stage design reduces pressure overshoot and cracking flow to a minimum, thus reducing power and production losses during high pressure operation.
- **Precise Control:** With the DENISON combined Seat Valve and Pilot design, and the range of springs available, it is possible to achieve extremely precise pressure setting.
- **Fast Response:** The favourable poppet mass to area ratio is especially advantageous, as it enables such features as fast response, high accuracy and quiet, flutter free control.
- **Wide Selection:** In addition to the three port flange mount valve, the ordering code offers a wide range of control options for valves and accessories.

### SYMBOL

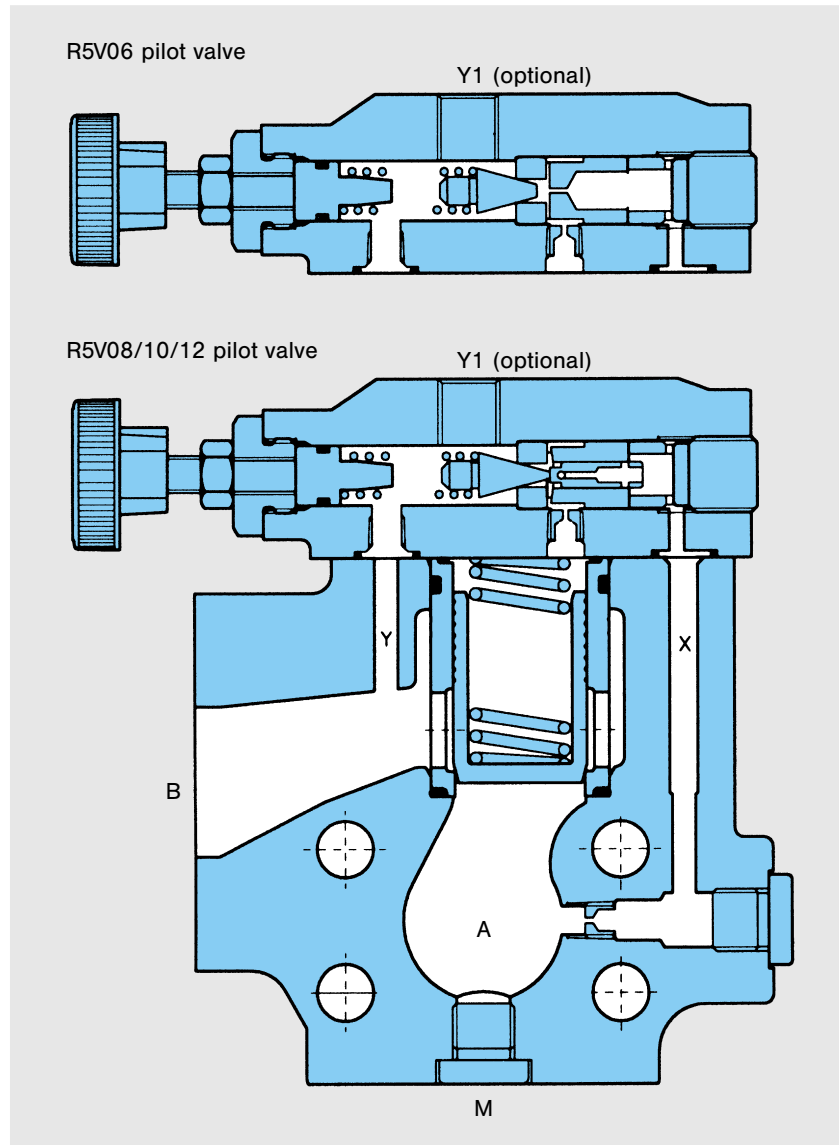
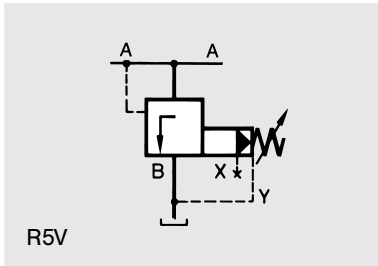

Example: R5V Pressure Relief Valve

## DESCRIPTION

### GENERAL DESCRIPTION

DENISON Pressure Valves are pilot operated controls consisting of two or three valve sections, either a high flow, poppet type seat valve section controlled by the low flow, adjustable pilot mounted on top or in the case of the Proportional Pressure Relief Valve, the proportional section P2 sandwiched between the pilot valve and the main body.

Pressure setting is achieved by means of a knurled knob or, if a tamperproof setting is required, by an acorn nut with lead seal. A proportional pressure setting is achieved according to the current input by R5V...P2.

### PRESSURE RELIEF VALVE

R5V pressure relief valves are used to limit the system pressure of a hydraulic system, in order to control the force exerted by a hydraulic actuator. The R5V valve may also be used to generate a pressure drop in a hydraulic circuit. Normally the pump is connected to Port A and the tank line to Port B.

### PRESSURE UNLOADING VALVE

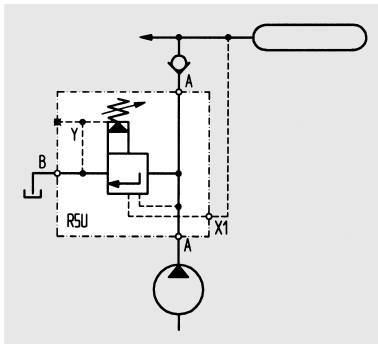

Accumulator system with Unloading Valve R5U

R5U pressure unloading valves are used to unload a circuit at low pressure when a port signal (Port X1) is maintained at a pressure that is higher than that of the pilot section. A typical application for an R5U is to unload a pump that is connected to an accumulator circuit. Another use for the R5U is to unload the low pressure side of a double pump.

In applications with an accumulator, it should be noted that the R5U and its accompanying check valve should be mounted as close to the accumulator as possible. This will prevent that the  $\Delta p$ , caused by long feed lines between the R5U and the accumulator, will reduce the selected 15 or 28% pressure differential (prevention of switching oscillations).

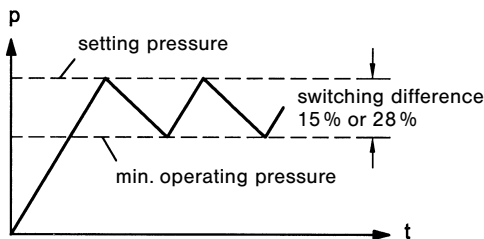

When the system pressure (in an accumulator for example) has fallen 15% or 28% below the pilot setting, the valve will close, and the pump flow will be restored to the hydraulic system.

$$R5U \dots 1/3 = 28\%$$

$$R5U \dots 5 = 15\%$$

**Note:** The mentioned switching difference values are theoretical and can vary between 12...15%, respectively between 20...28%.

### SEQUENCE VALVE

The R5S valve enables a hydraulic system to operate in a pressure sequence. After system pressure connected to Port A has reached a preadjusted value, fluid is allowed to pass through Port B to a secondary system.

### NOTE

DENISON flange valves enable the realisation of complete control systems. In addition to the valves discussed in this publication, the following flange valves are also available:

- R5 pressure valves with 2 ports	Publication
- F5C flow controls & R5A, R5P compensators	3-EN 2850
- C5V check valves, direct operated	5-EN 4200
- C5P check valves, direct & pilot operated	6-EN 4660
- D5S seat valves with 2 ports	6-EN 4700
- D5S seat valves with 3 ports	7-EN 520
	7-EN 530

## TECHNICAL DATA

### GENERAL

- Design Poppet type
- Type of mounting Flanged according to SAE-61  
e.g. directly on a pump  
(R5V12 according to SAE-62)  
3/4", 1", 1 1/4", 1 1/2" (only R5V, R5U)
- Port sizes
- Mounting position Optional
- Direction of flow A→B
- Ambient temperature range – 20... + 60 °C
- Suitability for special working conditions Consult DENISON

### HYDRAULIC CHARACTERISTICS

- Operating pressure
  - Inlet (Port A)
 

... 350 bar	R5*06/08
... 350 bar	R5V12 (SAE 62)
... 280 bar	R5*10
... 210 bar	R5U(V)12 (SAE 61)
  - Outlet (Port B)
 

... 30 bar	R5U, R5V
... 210, 280, 350 bar	R5S, R5U, R5V
	R5S: p at B < at A
  - Port X ... 210, 280, 350 bar
  - Ports Y, Y1 ... 30 bar
- Pressure setting range
  - min  $\geq 3$  bar
  - max 210, 280, 350 bar
- Max. flow
 

R5*06	R5*08	R5*10	R5V, R5U12
3/4"	1"	1 1/4"	1 1/2"
90 l/min	300 l/min	600 l/min	600 l/min
- Nominal flow depends on pump delivery
- Fluid Mineral oil according to DIN 51524/25  
(other fluids on request)
- Contamination level Max. permissible contamination level  
according to NAS 1638 Class 8  
(Class 9 for 15 Micron and smaller)  
or ISO 17/14
- Fluid temperature range – 18... + 80 °C
- Viscosity range 10... 650 cSt; optimal 30 cSt

### TYPE OF ACTUATOR

- **Manual**
- Rotation 3.75 x 360°
- Operation torque 72 Ncm
- **Electric**
- Nominal voltage Refer to ordering code page 5
- Permissible voltage difference + 5%... – 10%
- Max. coil temperature + 180 °C (temperature class H)
- Type of current Alternating current (AC)  
or direct current (DC)
- Input power 31 W
- Holding 78 VA
- Inrush 264 VA
- Relative operating period 100 %
- Type of protection IP 65
- **Electric proportional**  
(Pilot stage P2) 0... 2.5 A  
(refer to publication 3–EN 2200)

## ORDERING CODE

	R5.	..	-	.	.	-	.	-	..	-	...	-	A	1	-	
	1	2	3	4	5	6	7	8	9	10	11	12	13			
<p><b>1 Series</b>  R5V = Pressure Relief Valve  R5U = Pressure Unloading Valve  R5S = Sequence Valve</p> <p><b>2 Size</b>  06 = 3/4"  08 = 1"  10 = 1 1/4"  12 = 1 1/2" (R5V, R5U only)</p> <p><b>3 Max. Pressure</b>  3 = 210 bar - SAE 61 flange (R5V/R5U12)  4 = 280 bar - SAE 61 flange (R5.10)  5 = 350 bar - SAE 61 flange (R5.06/08)  6 = 350 bar - SAE 62 flange (R5V12 only)</p> <p><b>4 Body</b>  Ports X1<sup>2)</sup>, Y1<sup>1)</sup>, M<sup>2)</sup>  3 = SAE-4 (7/16"-20 UNF)  9 = G 1/4"  <sup>1)</sup> Port Y1 is only available at external PD (codes 4 &amp; 6) from the pilot head  <sup>2)</sup> closed when supplied</p> <p><b>5 Pressure Setting Range</b>  1 = ... 105 bar (R5U: Pressure differential 28%)  3 = ... 210 bar (R5U: Pressure differential 28%)  5 = ... 350 bar (R5U: Pressure differential 15%)</p> <p><b>6 Type of Control</b>  1 = Hand knob 32 mm dia.  2 = Hand knob 50 mm dia. (not for version with vent valve VV01 or P2)  3 = Acorn nut with lead seal  4 = Adjusting device with key lock (key order no. 700-70619-8)</p> <p><b>7 Pilot Connection</b>  2 = Internal PD - internal PP (R5V)  4 = External PD - external PP* (R5U)  5 = Internal PD - external PP* (R5U)  6 = External PD - internal PP (R5V, R5S)  * External pilot pressure connection on flange face (port X2)</p> <p><b>8 3-Way Vent Valve VV01</b>  09 = with manual override } Solenoid de-energized: open to tank  10 = without manual override } Solenoid energized: vent line blocked  11 = with manual override } Solenoid de-energized: vent line blocked  12 = without manual override } Solenoid energized: open to tank</p> <p><b>9 P2 = Electric Proportional Pressure Control</b> (12 V DC only, R5V only)</p> <p><b>10 Solenoid Voltage and Current</b>  W01 = 115 V / 60 Hz }  W02 = 230 V / 60 Hz } AC }  W06 = 115 V / 50 Hz }  W07 = 230 V / 50 Hz }  G0R = 12 V } DC  G0Q = 24 V }  G0H = 48 V }  <sup>1)</sup> R5V....P2 = 12 V DC only</p> <p><b>11 Design Letter</b></p> <p><b>12 Seal Class</b>  1 = NBR (Buna N) Standard    4 = EPDM    5 = VITON®</p> <p><b>13 Modifications</b></p>	<div style="text-align: center; border: 1px solid black; padding: 2px; width: fit-content; margin: 0 auto;">             omit              for version              without VV01              &amp; without P2         </div>															

# CURVES

## p-Q-CURVES

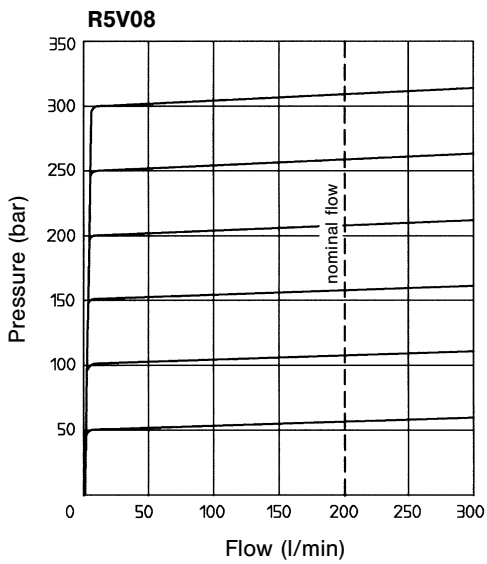
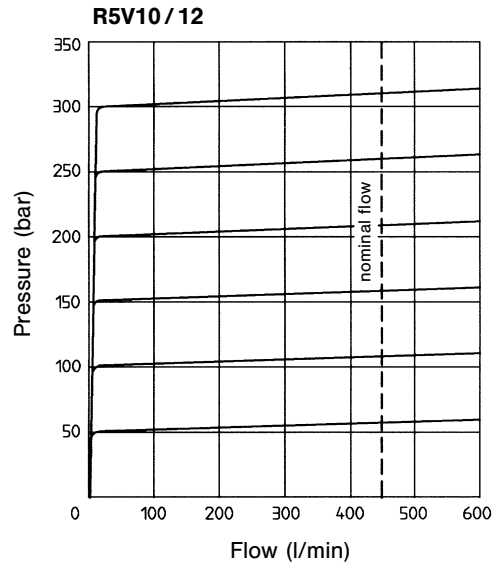
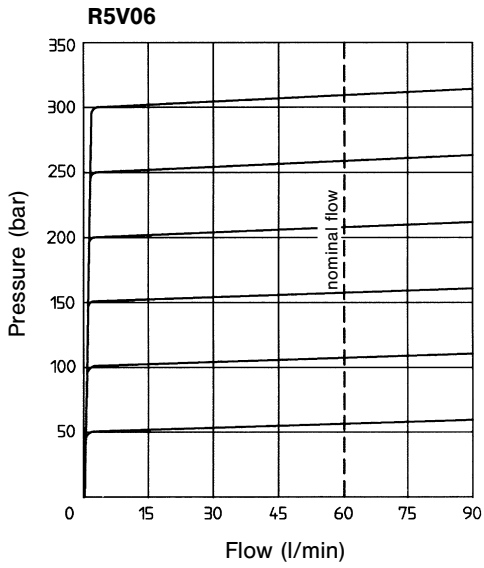

Min. pressure setting  $\geq 4$  bar  
(depending on flow and viscosity).  
Fluid 40 cSt and  $50^{\circ}\text{C} \pm 0.5^{\circ}\text{C}$ .

# CURVES

Unloading Function  
free flow P-T

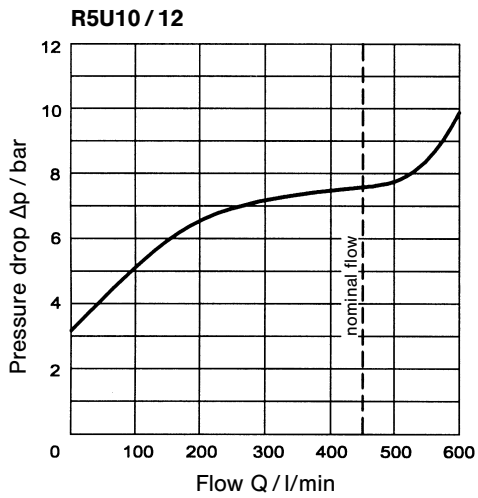
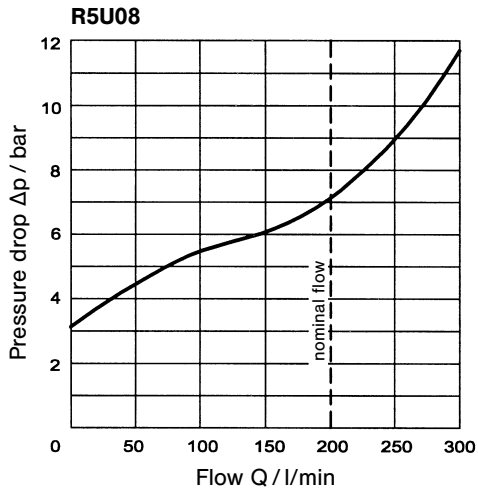
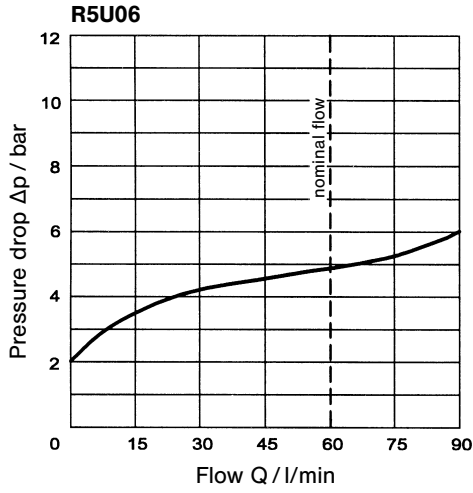

Min. pressure setting  $\geq 4$  bar  
(depending on flow and viscosity).  
Fluid 40 cSt and  $50^\circ\text{C} \pm 0.5^\circ\text{C}$ .

Overridden Pressure Relief Function

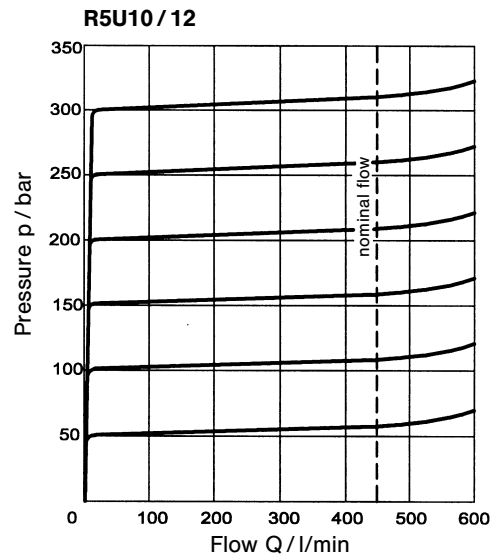
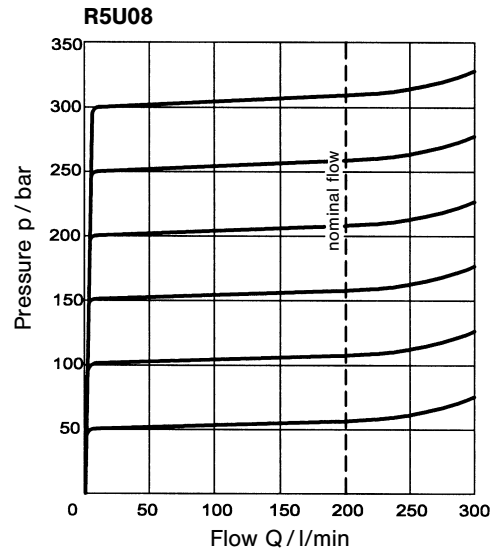
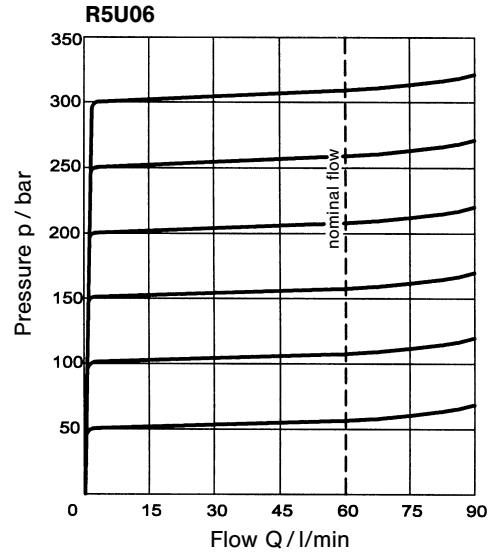

## R5V 06 – R5U 06 – R5S 06 (3/4")

Weight: 3.6 kg

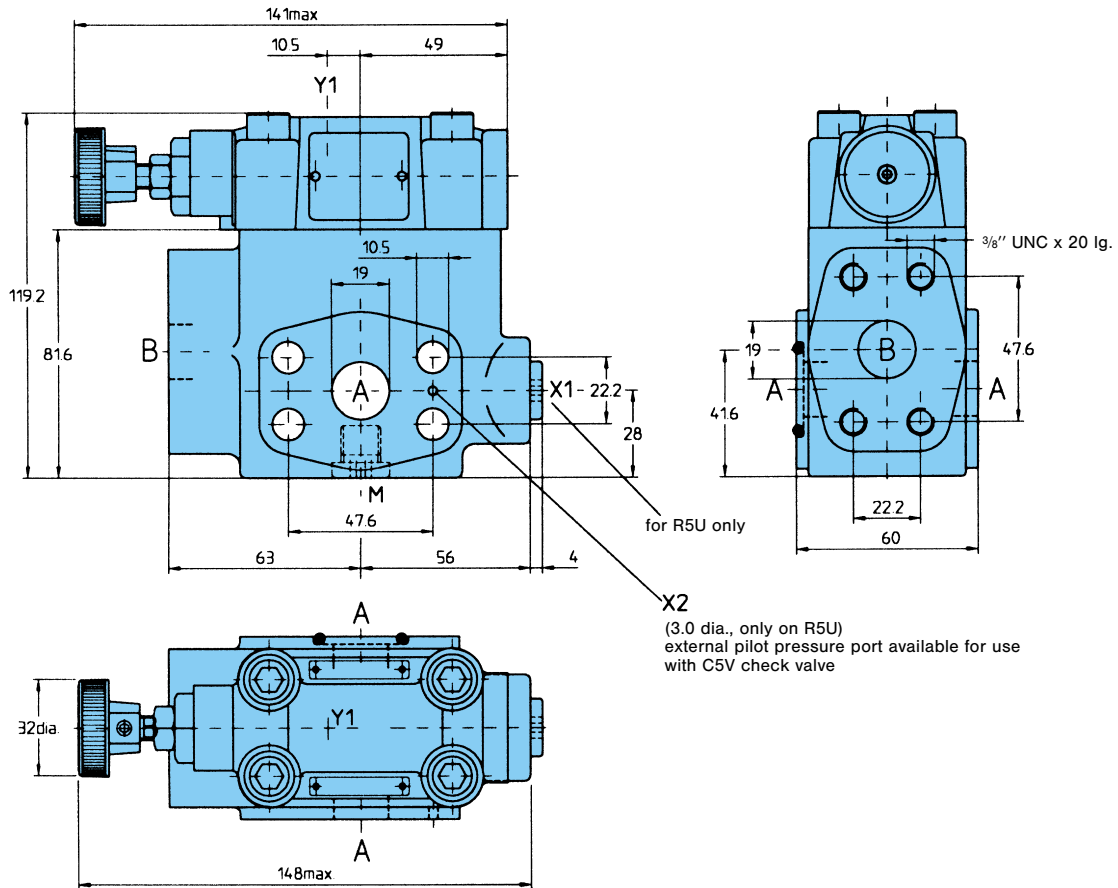

Ports	Function	Port sizes	R5V	R5U	R5S
A (2x)	Pressure	3/4" (SAE-61)	●	●	●
B	Tank <sup>2)</sup>	3/4" (SAE-61)	●	●	●
X1	ext. pilot port <sup>1)</sup>	G 1/4" or SAE-4		●	
Y1	ext. drain	G 1/4" or SAE-4	●	●	●
M	Pressure gauge	G 1/4" or SAE-4	●	●	●

<sup>1)</sup> closed when supplied

<sup>2)</sup> secondary port on R5S

**Note:**

R5\*06 pressure controls are mounted directly on the "B" cartridge of DENISON vane pumps and axial piston pumps PVT6.



## R5V08 – R5U08 – R5S08 (1")

Weight: 4.6 kg

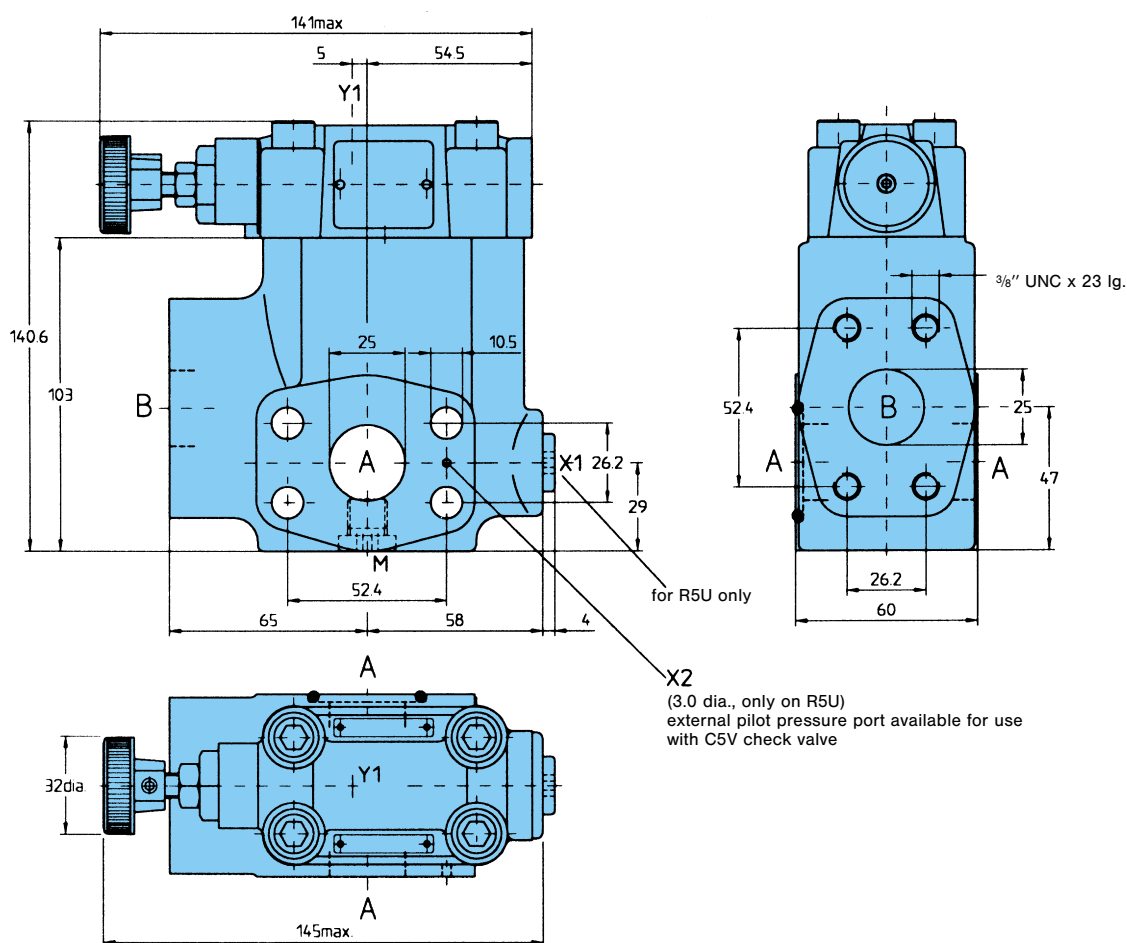

Ports	Function	Port sizes	R5V	R5U	R5S
A (2x)	Pressure	1" (SAE-61)	●	●	●
B	Tank <sup>2)</sup>	1" (SAE-61)	●	●	●
X1	ext. pilot port <sup>1)</sup>	G 1/4" or SAE-4	●	●	●
Y1	ext. drain	G 1/4" or SAE-4	●	●	●
M	Pressure gauge	G 1/4" or SAE-4	●	●	●

<sup>1)</sup> closed when supplied

<sup>2)</sup> secondary port on R5S

**Note:**

R5\*08 pressure controls are mounted directly on the "C" cartridge of DENISON vane pumps and axial piston pumps PVT10...29.

## R5V 10 – R5U 10 – R5S 10 (1 1/4")

Weight: 5.2 kg

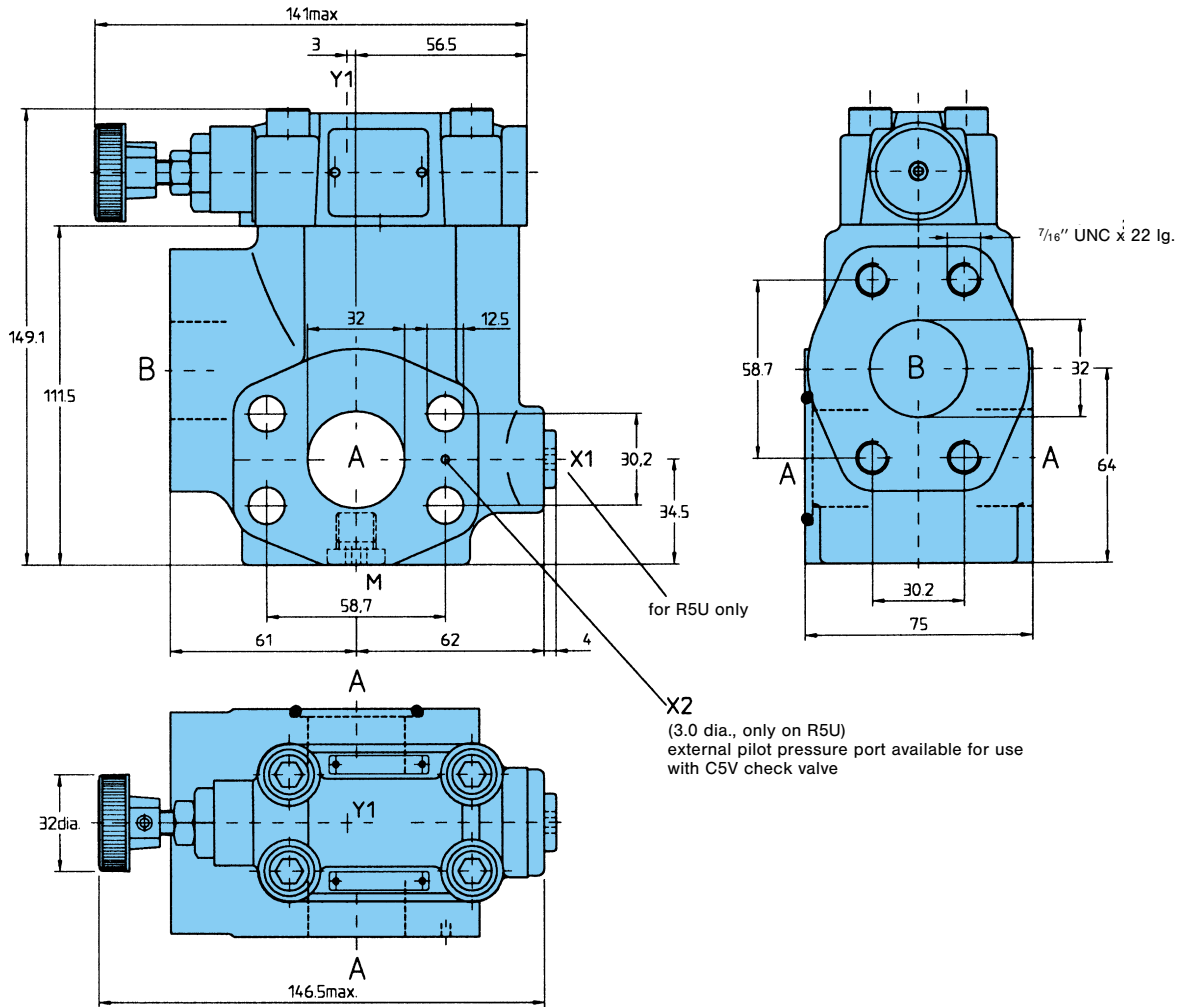

Ports	Function	Port sizes	R5V	R5U	R5S
A (2x)	Pressure	1 1/4" (SAE-61)	●	●	●
B	Tank <sup>2)</sup>	1 1/4" (SAE-61)	●	●	●
X1	ext. pilot port <sup>1)</sup>	G 1/4" or SAE-4		●	
Y1	ext. drain	G 1/4" or SAE-4	●	●	●
M	Pressure gauge	G 1/4" or SAE-4	●	●	●

<sup>1)</sup> closed when supplied

<sup>2)</sup> secondary port on R5S

**Note:**

R5\*10 pressure controls are mounted directly on the "D" cartridge of DENISON vane pumps.

## R5V 12 – R5U 12 (1½")

Weight: 8 kg

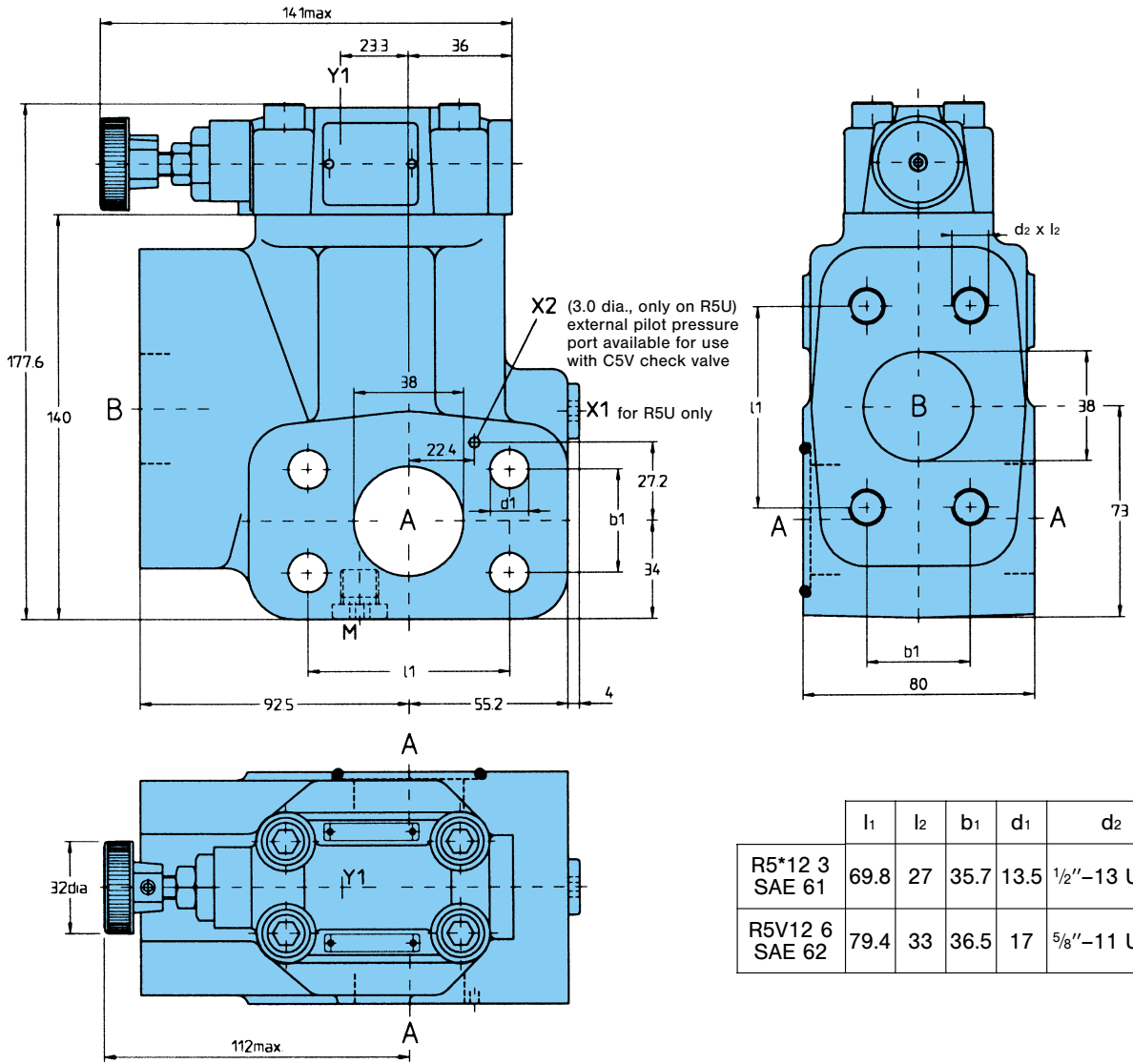

	l <sub>1</sub>	l <sub>2</sub>	b <sub>1</sub>	d <sub>1</sub>	d <sub>2</sub>
R5*12 3 SAE 61	69.8	27	35.7	13.5	½"-13 UNC
R5V12 6 SAE 62	79.4	33	36.5	17	⅝"-11 UNC

Ports	Function	Port sizes	R5V	R5U
A (2x)	Pressure	1½" (SAE-61/62)	●	●
B	Tank	1½" (SAE-61/62)	●	●
X1	ext. pilot port <sup>1)</sup>	G ¼" or SAE-4		●
Y1	ext. drain	G ¼" or SAE-4	●	●
M	Pressure gauge	G ¼" or SAE-4	●	●

<sup>1)</sup> closed when supplied

### Notes

- R5\*12 3 – SAE 61 mounted directly on the "E" cartridge of DENISON vane pumps.
- R5V12 6 – SAE 62 mounted directly on the DENISON axial piston pumps series "World-Cup" and "Premier".

## ADDITIONAL TYPES OF CONTROLS, SYMBOLS

### ADDITIONAL TYPES OF CONTROLS

**Type of Control-Code 2**  
Hand knob 50 mm dia.  
(not for version with  
vent valve VV01 or P2)

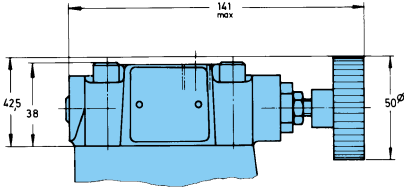

**Type of Control-code 3**  
Acorn nut with lead seal

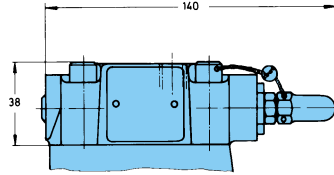

**Type of Control-Code 4**  
Adjusting device with key lock.  
Key must be ordered separately  
order-no. 700-70619-8

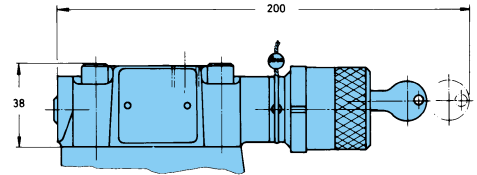

### SYMBOLS

Internal  
Drain

External  
Drain

Pressure Relief Valve R5V

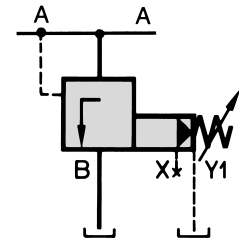
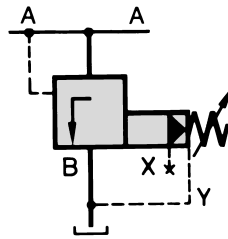

Pressure Unloading Valve R5U

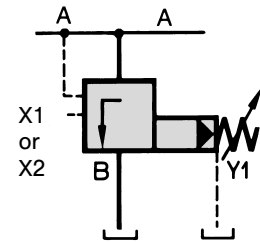
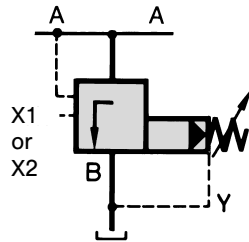

Sequence Valve R5S

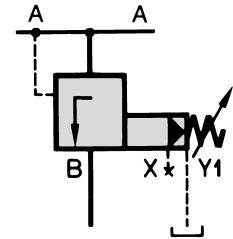

## VERSION WITH VENT VALVE VV01

Weight (VV01): 1.7 kg

Screws for additional vent valve installation.  
4 x 3/8"-24 UNF x 3 1/2" lg., order no. 359-15340-0.

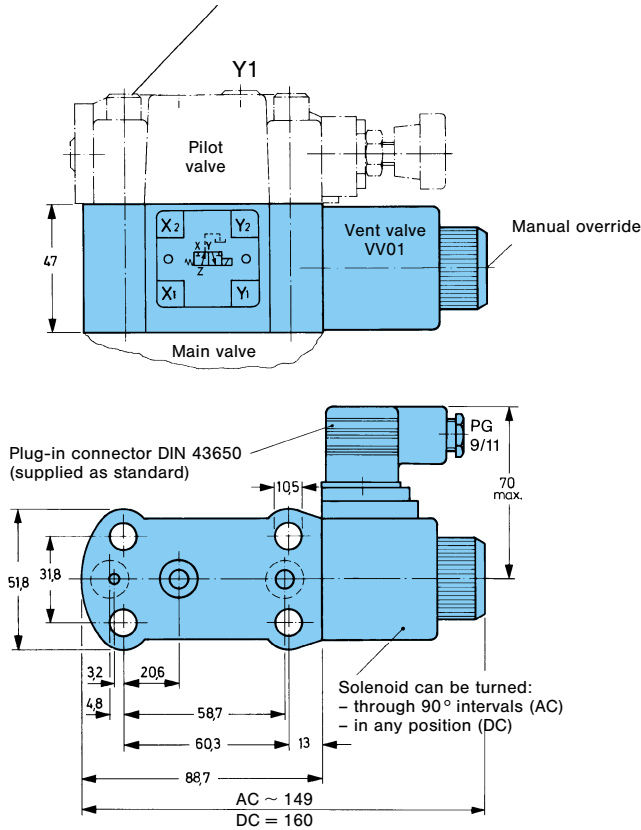

**Note:**  
Details for vent valve VV01 see publication 3-EN 215.

**Symbols:**

R5\* - Pressure Controls with Vent Valve VV01

Code	Pressure Relief Valve R5V		Pressure Unloading Valve R5U		Sequence Valve R5S
	Internal Drain	External Drain	Internal Drain	External Drain	External Drain
11 or 12					
09 or 10					

## PROPORTIONAL PRESSURE RELIEF VALVE R5V... P2

Screws for additional proportional section installation  
 4 x 3/8"-24 UNF x 3 1/2" lg., Order No. 359-15340-0.

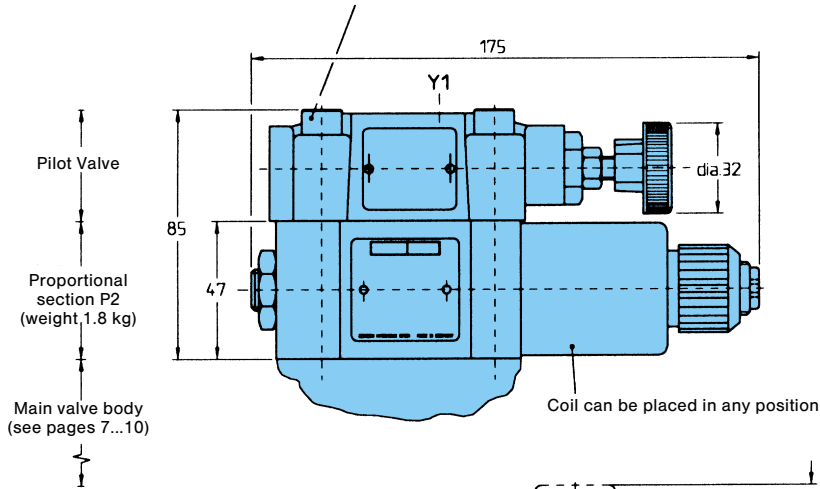

**Drain line**

Only external from the pilot head (Y1).

**The pilot drain port must be connected to a stable low pressure tank line. Pressure variations in the drain port should be avoided.**

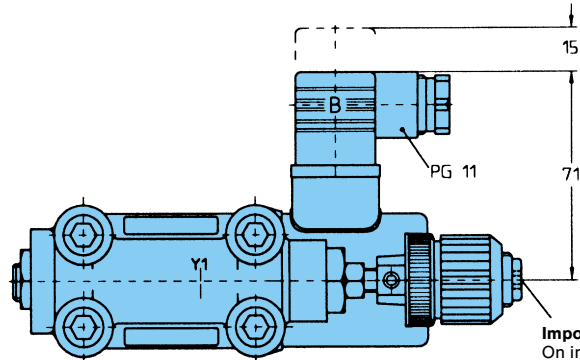

Distance required to remove plug-in connector. Plug-in connector supplied as standard.

**Symbol**

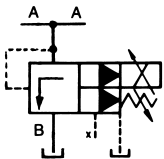

**Important:**

On initial start up and after long shut down periods bleed air from this plug.

**Note:**

See publication 3-EN 2200 for information on Electrical Proportional Control Valve. For additional installation with pilot operated control valves please consult DENISON.

## SAE-FLANGES

**Inlet flange**  
(only for  
pipe mounting)  
available with  
UNC-threads only

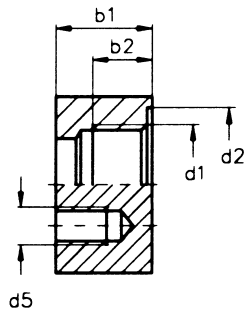
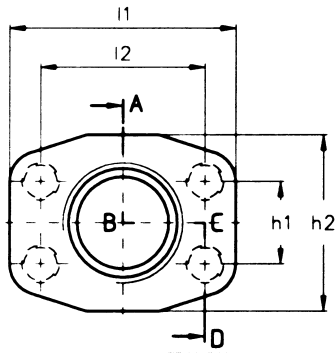

with G-thread

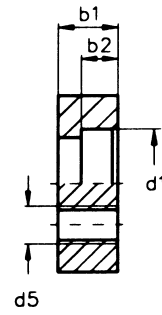

socket weld

**Outlet and  
tank port  
flange**

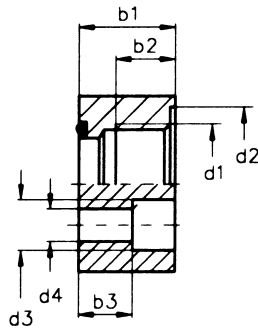
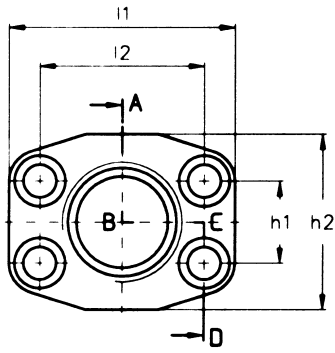

with G-thread

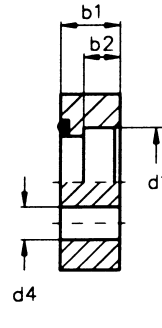

socket weld

Port sizes d <sub>1</sub>	Inlet flange (without screws*) only for pipe mounting	Outlet flange (without screws*)	Tank port flange (with screws)											
	Order No.	Order No.	Order No.	l <sub>1</sub>	l <sub>2</sub>	b <sub>1</sub>	b <sub>2</sub>	b <sub>3</sub>	h <sub>1</sub>	h <sub>2</sub>	d <sub>2</sub> ∅	d <sub>3</sub> ∅	d <sub>4</sub> ∅	d <sub>5</sub>
G 3/4" <sup>1)</sup> 3/4" socket weld	S16-86520-0	S16-86529-0	S14-66933-0	67	47.6	34	15.9	22	22.2	52	40	16.5	10.5	3/8" UNC
	S16-86519-0	S16-86528-0	S14-66941-0			19	12	-			-	-		
G 1" <sup>1)</sup> 1" socket weld	S16-86523-0	S16-86532-0	S14-66934-0	72	52.4	34	20	22	26.2	58	46	16.5	12.5	7/16" UNC
	S16-86522-0	S16-86531-0	S14-66942-0			24	14	-			-	-		
G 1 1/4" <sup>1)</sup> 1 1/4" socket weld	S16-86526-0	S16-86535-0	S14-66935-0	80	58.7	39	22	24	30.2	73	54	17.5	14.5	1/2" UNC
	S16-86525-0	S16-86534-0	S14-66943-0			24	14	-			-	-		
G 1 1/2" <sup>1)</sup> 1 1/2" socket weld	S26-52364-0	S26-52215-0	S14-66936-0	94	69.8	39	24	24	35.7	82	60	20	17.5	5/8" UNC
	S26-52366-0	S26-52217-0	S14-66944-0			26	16	-			-	-		
G 1 1/2" <sup>2)</sup> 1 1/2" socket weld	464-01147-0	464-01141-0	464-01004-0	112	79.4	50	28	30	36.5	94	60	25	17.5	5/8" UNC
	464-01149-0	464-01143-0	464-01146-0			-	-	-			-	-		

<sup>1)</sup> SAE 61

<sup>2)</sup> SAE 62

\* see pages 15 and 16 for screws

# MOUNTING INSTRUCTIONS FOR SAE 61-VALVES

## Example

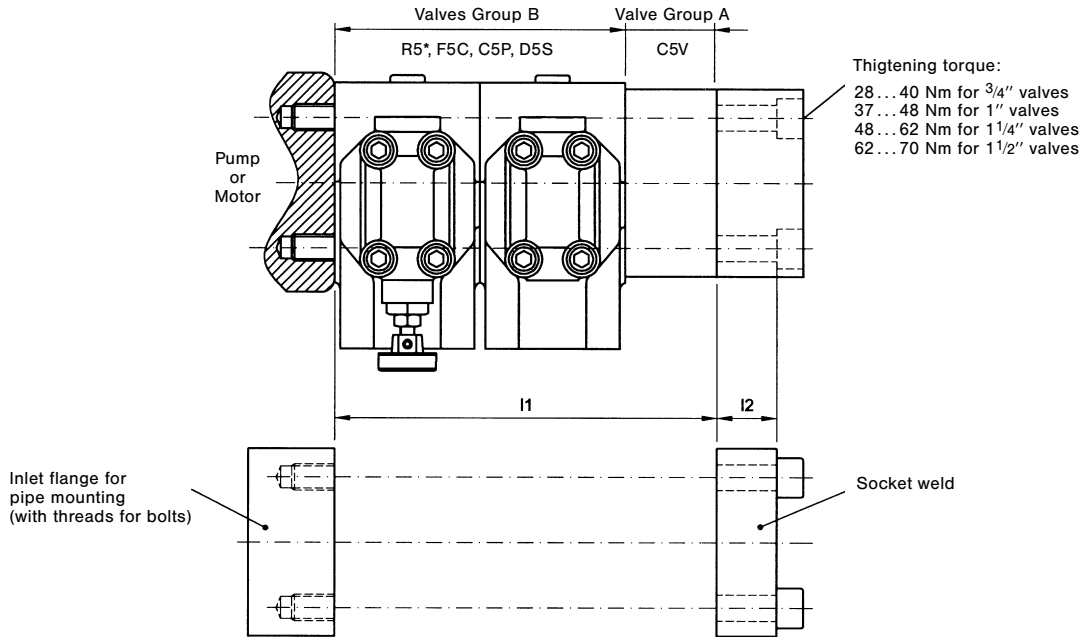

	Qty. of valves and group for each stack	I1	I2	UNC-Screws (12.9)		Metric Screws (12.9)	
				Dimension	Order No.	Dimension	Order No.
3/4" SAE 61	1 x A	45	16...22	3/8"-16 x 3 1/4"	358-16330-0	M10 x 80	361-11324-8
	1 x B	60		3/8"-16 x 3 3/4"	358-16350-0	M10 x 95	361-11354-8
	(1 x A) + (1 x B)	105		3/8"-16 x 5 1/2"	358-16420-0	M10 x 140	361-11424-8
	2 x B	120		3/8"-16 x 6"	358-16440-0	M10 x 160	700-70836-8
	(1 x A) + (2 x B)	165		3/8"-16 x 8"	358-16520-0	M10 x 200	700-70821-8
	3 x B	180		3/8"-16 x 8 1/2"	358-16540-0	M10 x 220	361-11494-8
1" SAE 61	1 x A	45	18...24	3/8"-16 x 3 1/4"	358-16330-0	M10 x 80	361-11324-8
	1 x B	60		3/8"-16 x 3 3/4"	358-16350-0	M10 x 95	361-11354-8
	(1 x A) + (1 x B)	105		3/8"-16 x 5 3/4"	358-16430-0	M10 x 140	361-11424-8
	2 x B	120		3/8"-16 x 6 1/4"	358-16450-0	M10 x 160	700-70836-8
	(1 x A) + (2 x B)	165		3/8"-16 x 8"	358-16520-0	M10 x 200	700-70821-8
	3 x B	180		3/8"-16 x 8 1/2"	358-16540-0	M10 x 220	361-11494-8
1 1/4" SAE 61	1 x A	50	21...25	7/16"-14 x 3 1/2"	358-18340-0	M12 x 90	361-12344-8
	1 x B	75		7/16"-14 x 4 1/2"	358-18380-0	M12 x 120	361-12404-8
	(1 x A) + (1 x B)	125		7/16"-14 x 6 1/2"	358-18460-0	M12 x 170	361-12454-8
	2 x B	150		7/16"-14 x 7 1/2"	358-18500-0	M12 x 190	361-12474-8
	(1 x A) + (2 x B)	200		7/16"-14 x 9 1/2"	358-18580-0	M12 x 240	361-12504-8
	3 x B	225		7/16"-14 x 10 1/2"	358-18590-0	M12 x 270	361-12664-8
1 1/2" SAE 61	1 x A	50	25...27	1/2"-13 x 3 3/4"	358-20350-0	M12 x 90	361-12344-8
	1 x B	80		1/2"-13 x 5"	358-20400-0	M12 x 130	361-12414-8
	(1 x A) + (1 x B)	130		1/2"-13 x 6 3/4"	358-20470-0	M12 x 170	361-12454-8
	2 x B	160		1/2"-13 x 8"	358-20520-0	M12 x 200	361-12484-8
	(1 x A) + (2 x B)	210		1/2"-13 x 10"	358-20600-0	M12 x 250	361-12674-8
	3 x B	240		1/2"-13 x 11 1/4"	358-20650-0	M12 x 290	361-12684-8



## MOUNTING INSTRUCTIONS FOR SAE 62-VALVES

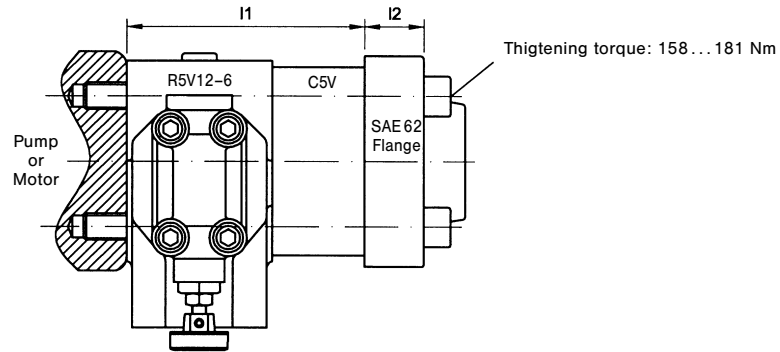

Series	Nominal Size	l1	l2	UNC-Screws (12.9)		Metric Screws (12.9)	
				Dimension	Order No.	Dimension	Order No.
R5V12-6	1 1/2"	80	30	5/8"-11 x 5 1/4"	358-24410-0	M16 x 130	361-14414-8
C5V12	1 1/2"	50	30	5/8"-11 x 4"	358-24360-0	M16 x 100	361-14364-8
R5V12-6 + C5V12	1 1/2"	130	30	5/8"-11 x 7"	358-24480-0	M16 x 180	361-14464-8

The product described is subject to continual development and the manufacturer reserves the right to change the specifications without notice.