

# Series P2/P3 Variable Volume Piston Pumps

Bulletin HY13-2656-B1/US



## General information

*The newly developed variable displacement piston pumps from Parker Hannifin, designated 'P2' and 'P3', are mainly intended for mobile applications.*

*The new pumpline is designed specifically for medium duty operation in off-road vehicles, featuring a very compact design, low noise level and low pressure ripple.*

*The P2 and the P3 are basically the same but the P3 offers, in addition, a built-in impeller to suit applications requiring higher selfpriming speeds, or when the vehicle is operating in high altitudes.*

*The pumps are very stable and respond quickly to system demands in many different types of mobile machinery, and they are designed for cost effective installation within the limited space available on modern mobile machines.*

*The P2/P3 pumpline is presently available in four frame sizes from 60 to 145 cm<sup>3</sup>/rev and features control options that are suitable for most off-road vehicle applications, and offers benefits like:*

- Compact - small envelop size
- Reduced pressure ripple - less noise
- Service friendly
- Reliable
- Long-lasting
- Flexible modular design
- Easy to install
- High selfpriming speed
- The risk of external leakage minimized.

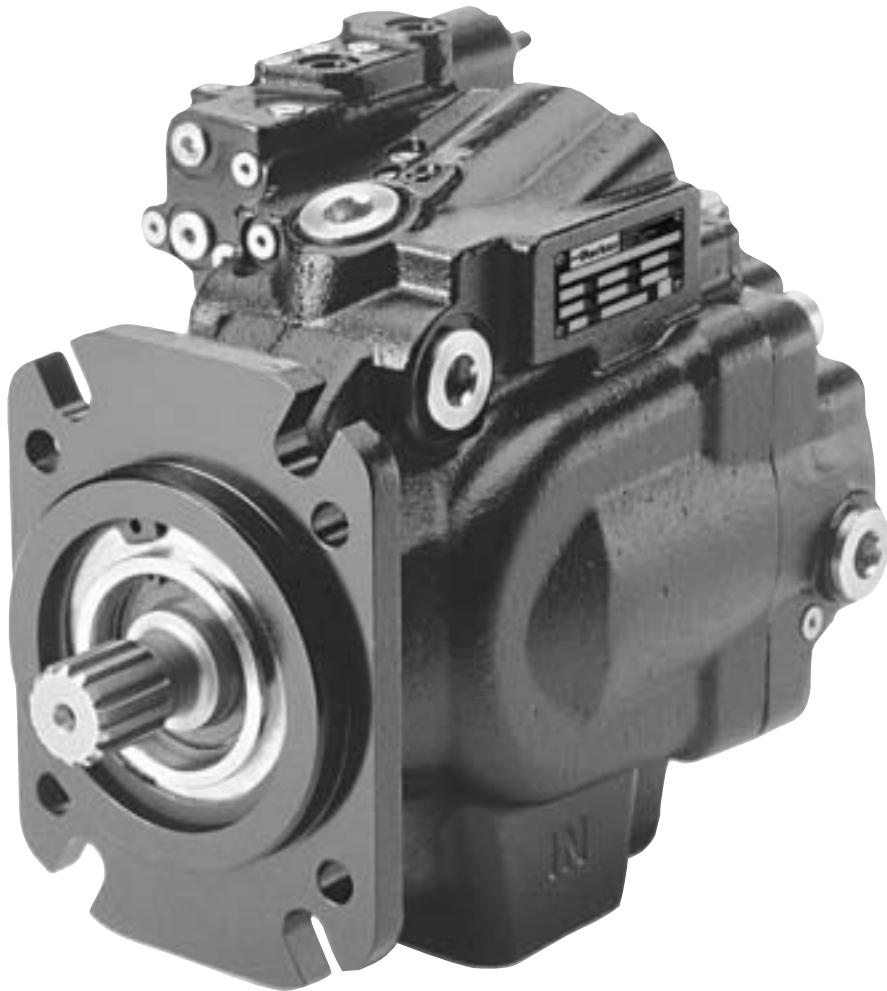

## Specifications

### Series P2 - standard version

Frame size	060	075	105	145
Max displacement [cm <sup>3</sup> /rev] [cu in/rev]	60 3.66	75 4.58	105 6.41	145 8.85
Selfpriming speed at 1 bar/15 psi (abs.) inlet pressure [rpm]	2 800	2 500	2 300	2 200
Main port location and	Side Rear	Side Rear	Side -	Side -

### Series P3 - supercharged version

Frame size	-	075	105	145
Max displacement [cm <sup>3</sup> /rev] [cu in/rev]	-	75 4.58	105 6.41	145 8.85
Selfpriming speed at 1 bar/15 psi (abs.) inlet pressure [rpm]	-	3 000	2 600	2 500
Main port location	-	Side	Side	Side

### Common data

Frame size	060	075	105	145
Max continuous pressure [bar] [psi]	320 4 600	320 4 600	320 4 600	320 4 600
Peak pressure [bar] [psi]	370 5 200	370 5 200	370 5 200	370 5 200
Noise level at full flow, 1 800 rpm, and 250 bar (3 600 psi) [dbA]	74	76	78	80
Weight with load sense control [kg] [lbs]	37 81	44 97	62 136	81 178

### Controls

Frame size	060	075	105	145
Load sensing with pressure cut-off	x	x	x	x
Torque control	-	x	x	x
Torque summation control	-	x	x	x
Pressure compensation	x	x	x	x
Remote pressure control	x	x	x	x

### Mounting flange and shaft

Frame size	060	075	105	145
SAE mounting flange Standard	'C' 4 bolt	'C' 2 and 4 bolt	'C' 2 and 4 bolt	'D', 4 bolt
SAE mounting flange Optional	'B' 2 bolt	-	-	'C' 2 bolt
SAE spline shaft Standard	'C'	'C'	'C'	'D'
SAE spline shaft Optional or	'B-B' 'B'	'C-C' -	'D' -	'C' -
Through-shaft capability	x	x	x	x

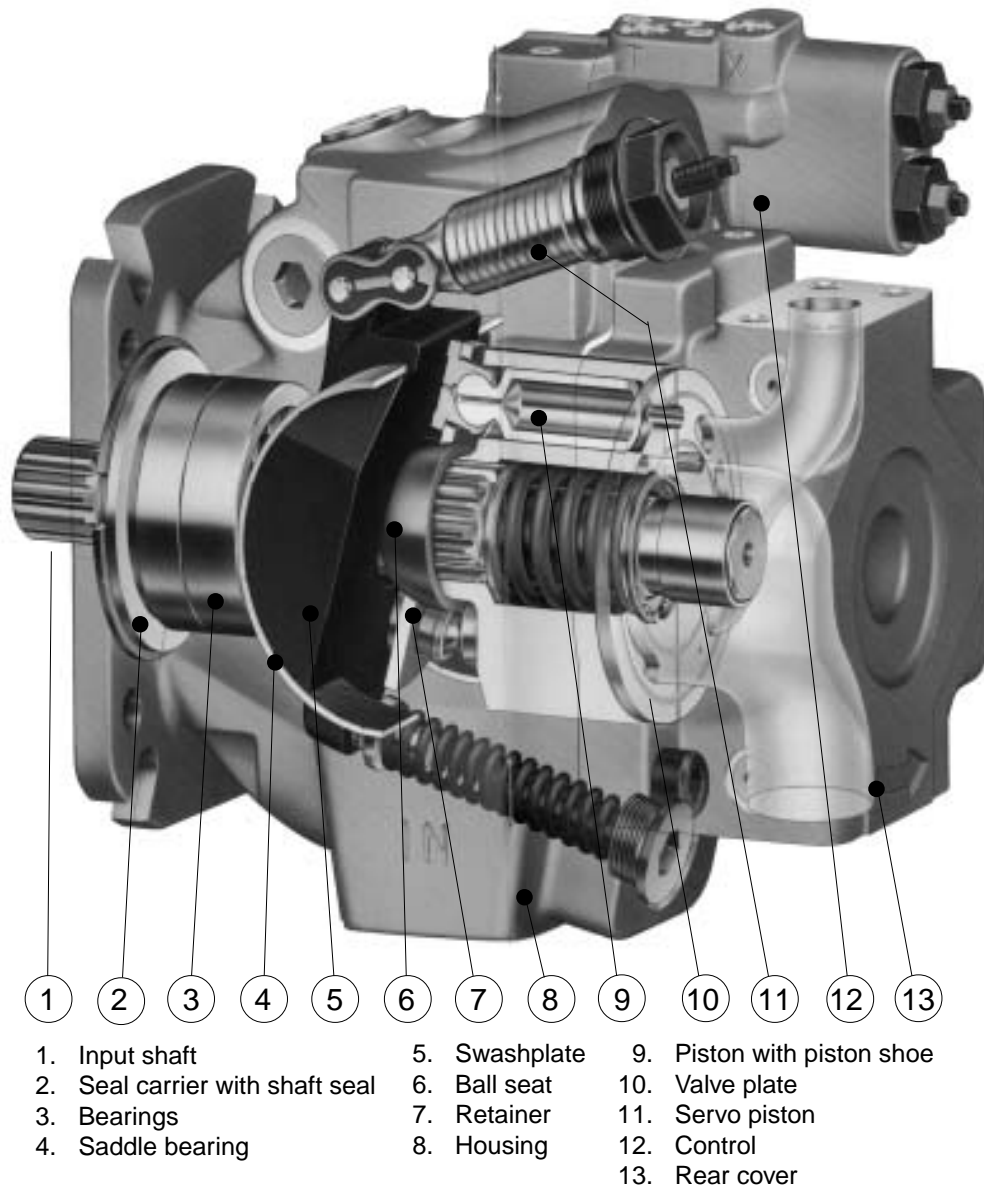

**P2 cut-away****New functionality adds value**

Parker has developed a line of pumps with a long service life which are compact, with a low noise level and a high selfpriming speed. Our new pump line also boasts a unique port layout and generates less pressure pulsations than previous designs.

**Compact and easy to install**

Attaching this pump to your machinery is easy because of its compact design and unique port layout. Normally, it will not require an off-set gearbox, which will lower the total installation cost.

**Less noise to insulate**

The rigid housing design, combined with the reduced pressure ripple, decreases airborne as well as hydraulically generated noise. These features will significantly reduce the needs for costly insulation.

**Reliable**

High selfpriming speed and the reduced pressure ripple increase the service life of the pump while lowering maintenance costs of the system.

**Flexible**

The modular design of the P2/P3 line will readily accommodate future control variations.

**Installation, series P2 with side ports**

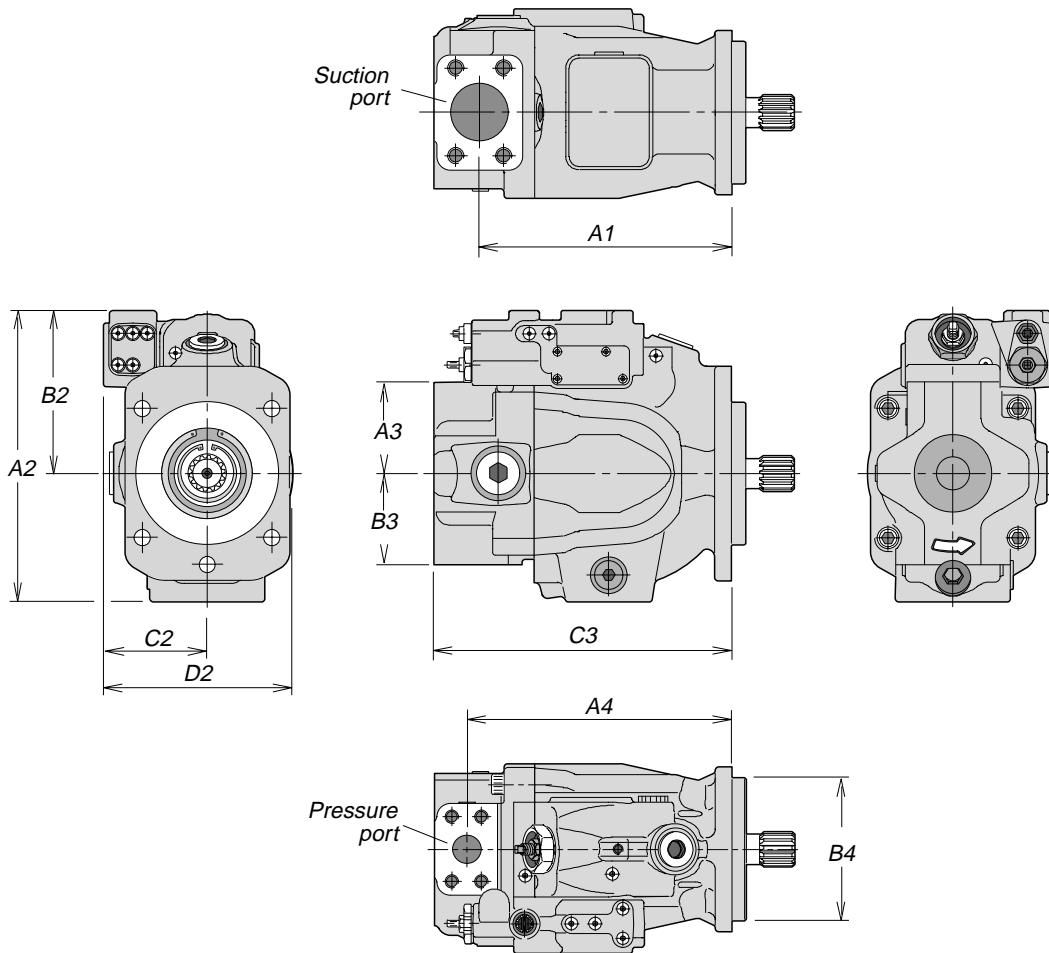

P2 frame size	060	075	145
A1 [mm]	224	254	284
[in]	8.82	9.98	1.15
A2	259	277	350
	10.18	10.91	13.76
B2	145	154	186
	5.69	6.06	7.30
C2	92	108	110
	3.62	4.25	4.33
D2	168	189	217
	6.61	7.44	8.54
A3	81	81	102
	3.19	3.19	4.02
B3	81	81	110
	3.19	3.19	4.33
C3	264	293	330
	10.39	11.52	12.97
A4	235	265	299
	9.25	10.41	11.75
B4	127.0/ 101.6	127.0	152.4/ 127.0
	5.00/ 4.00	5.00	6.00/ 5.00

P2 frame size	060	075	145
Suction port	2"	2"	2 1/2"
Pressure port	1"	1"	1 1/4"

**NOTE:** Contact Parker Hannifin, Hydraulic Pump/Motor Division, for additional installation information

**Installation, series P2 with rear ports**

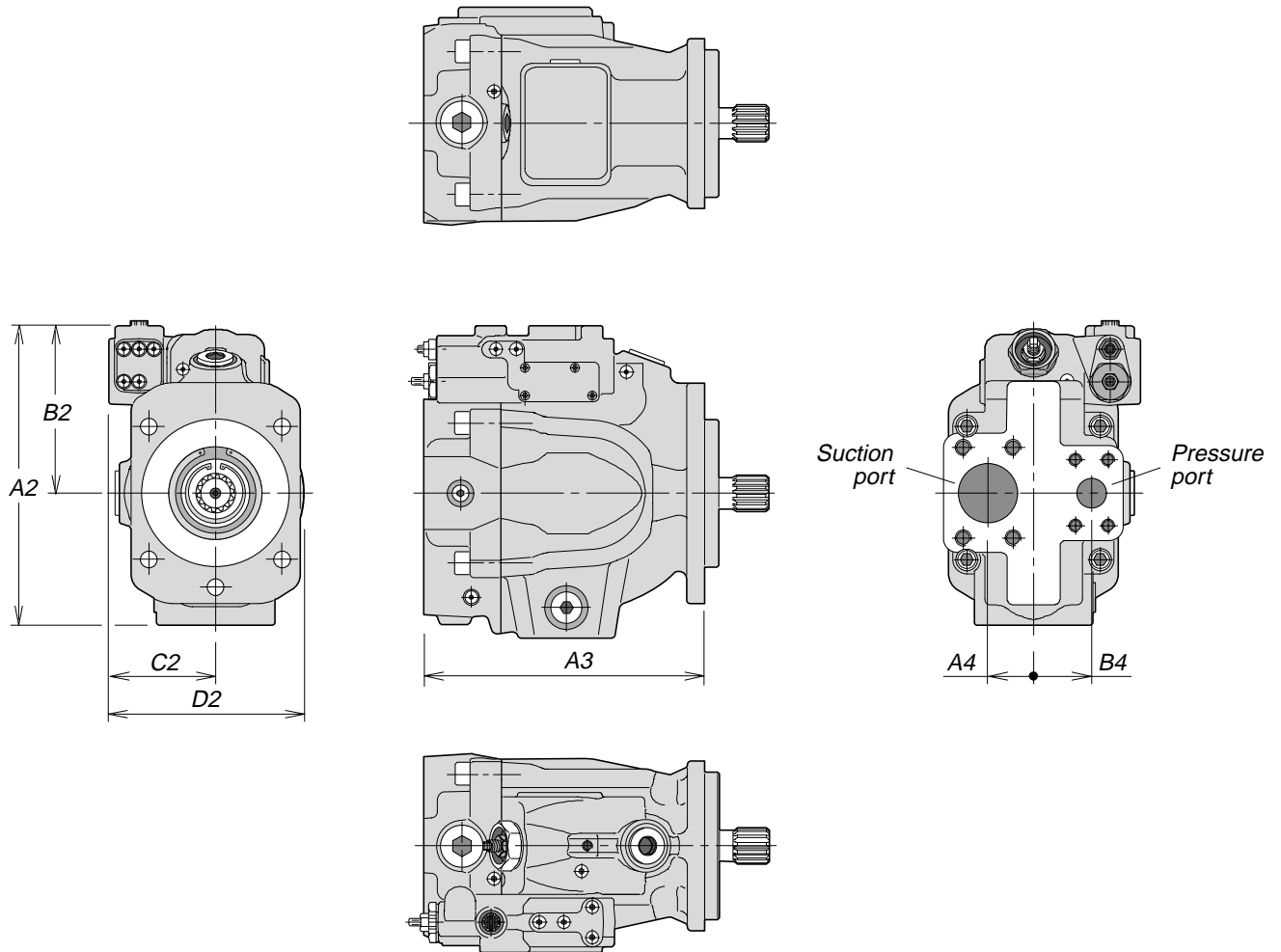

P2 frame size	060	075
A2 [mm]	259	259
[in]	10.18	10.18
B2	145	145
	5.71	5.71
C2	92	92
	3.62	3.62
D2	171	190
	6.74	7.47
A3	241	271
	9.49	10.65
A4	39	39
	1.54	1.54
B4	50	52
	1.97	2.05

P2 frame size	060	075
Suction port	2"	2"
Pressure port	1"	1"

**NOTE:** Contact Parker Hannifin, Pump/Motor Division, for additional installation information

**Installation, Series P3 (supercharged version)**

**A**

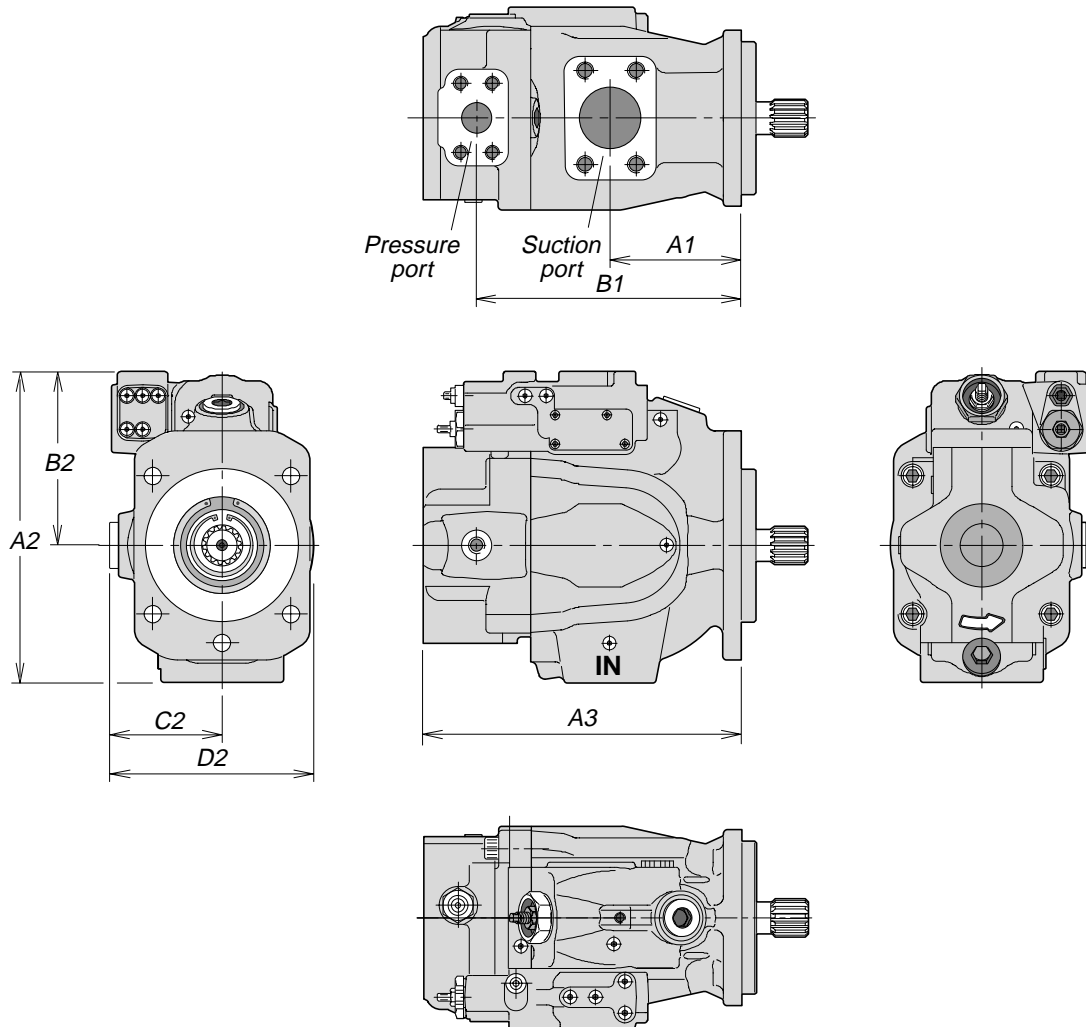

P3 frame size	075	145	P3 frame size	075	145
A1 [mm]	129	127	Suction port	2"	2 1/2"
[in]	5.08	5.00	Pressure port	1"	1 1/4"
B1	241	270			
	9.49	10.63			
A2	274	347			
	10.79	13.64			
B2	154	186			
	6.06	7.30			
C2	108	110			
	4.25	4.33			
D2	195	227			
	7.68	8.96			
A3	276	317			
	10.87	12.48			

**NOTE:** Contact Parker Hannifin, Pump/Motor Division, for additional installation information

Ordering code

Example:

<b>P2</b>	<b>075</b>	<b>L</b>	<b>02</b>	<b>N1</b>	<b>C</b>	<b>100</b>	<b>L</b>	<b>B</b>	<b>1</b>	<b>NO</b>	<b>U</b>	<b>OO</b>	<b>S</b>
1	2	3	4	5	6	7	8	9	10	11	12	13	14

1. Pump series

- P2** Standard
- P3** Supercharged

2. Displacement [cm<sup>3</sup>/rev]

	Standard	Supercharged
<b>060</b>	60	-
<b>075</b>	75	75
<b>105</b>	105	105
<b>145</b>	145	145

3. Shaft rotation

- (viewed towards shaft end)
- R** Clockwise (right hand)
- L** Counter clockwise (left hand)

4. Shaft end (all are SAE)

Description	060	075	105	145
01 Spline	'B'	x	x	x
02 Spline	'B-B'	x	x	x
03 Spline	'C'	'C'	'C'	'C'
04 Spline	x	'C-C'	x	x
05 Spline	x	x	D	'D'
08 Keyed	'C'	'C'	'C'	x
09 Keyed	x	'C-C'	'C-C'	x
10 Keyed	x	x	x	'D'

5. Seal type

- N1** Nitrile, 1 seal
- N2** Nitrile, 2 seals with 'tell tale'
- V1** Fluorocarbon, 1 seal
- V2** Fluorocarbon, 2 seals with 'tell tale'

6. Mounting flange (all are SAE)

	060	075	105	145
<b>B</b> 'B', 2 bolt	x	x	x	x
<b>C</b> 'C'	'C'	'C'	'C'	'C'
	4 bolt	2 and 4 bolt	2 and 4 bolt	2 bolt
<b>D</b>	x	x	x	'D', 4 bolt

7. Pressure setting (pressure relief valve)

- 100** Setting of pressure cut-off valve [bar] (100–320 bar/1450–4600 psi)

8. Control

- L1** Load sensing with pressure cut-off
- R1** Remote pressure
- P1** Pressure cut-off
- T1** Torque/load sensing and pressure cut-off
- T2** Torque summation/load sensing and pressure cut-off

9. Bleed-off orifice

- N** No orifice
- W** Bleed-off orifice

10. Main ports (location/screw thread)

	060		075		105		145	
	P2	P3	P2	P3	P2	P3	P2	P3
<b>1</b> Side/UNC	x	x	x	x	x	x	x	x
<b>2</b> Side/Metric	(x)	(x)	(x)	(x)	(x)	(x)	(x)	(x)
<b>3</b> Rear/UNC	(x)	(x)	-	-	-	-	-	-
<b>4</b> Rear/Metric	(x)	(x)	-	-	-	-	-	-

11. Through drive (mounting flange and coupling)

	Mounting fl.	Coupling	060	075	105	145
<b>NO</b>	-	-	No through drive			
<b>N1</b> Prepared for through drive; no coupling			(x)	(x)	(x)	(x)
<b>A1</b> 'A', 2 bolt	'A' spline		(x)	(x)	(x)	(x)
<b>B1</b> 'B', 2 bolt	'B' spline		(x)	(x)	(x)	(x)
<b>B2</b> 'B', 2 bolt	'B-B' spline		(x)	(x)	(x)	(x)
<b>C1</b> 'C', 2 bolt	'C' spline		(x)	(x)	(x)	(x)
<b>C2</b> 'C', 2 bolt	'C-C' spline		-	-	-	(x)
<b>C3</b> 'C', 4 bolt	'C' spline		(x)	(x)	(x)	(x)
<b>C4</b> 'C', 4 bolt	'C-C' spline		-	-	-	(x)
<b>D3</b> 'D', 4 bolt	'D' spline		-	-	-	(x)

12. Paint option

- (U)** No painting
- P** Pump to be painted

13. Special version number (factory issued)

- OO** No Special Modifications

\*14. Multiple pump assembled at factory

- (S)** Single pump
- (F)** Front pump
- (M)** Middle pump
- (R)** Rear pump

x (or text) Available	(x) Optional	- Not available
--------------------------	-----------------	--------------------

**NOTE:** Adjustable settings to be specified in clear text;  
Torque settings in Nm (1 Nm equals 0.738 lbf ft)  
Δp (differential pressure) setting:  
- Standard 20 bar (≈ 300 psi)  
- Range 10–35 bar (≈ 150–500 psi).

\*-Multiple pump assemblies must be ordered on the same purchase order and must only be comprised of pumps manufactured in Otsego, MI plant.